



Safer and Simpler Material Handling

Standard Davit Features

- Available with AC, DC, pneumatic, hydraulic, and manual hoists
- Four-position extendable boom for flexible operation
- Turnbuckle boom angle adjustment
- 360° rotation in pedestal, socket or wall mounted bases
- Top and bottom sleeve bearings in base allow for ease of rotation when under load
- Powder coated frame and components
- Stainless steel models available

Options

- Swing handle
- Upper limit switch
- Overhaul plate
- Rotary limit switch with adjustable lower limit
- Weather resistant coatings and hardware
- Additional features and upgrades available upon request

Distributed by:

Columbia Davit Cranes can be built to meet the needs of virtually any material handling application. Contact us today with your specific requirements.

CAUTION: The final determination as to the suitability of this product for any purpose is solely that of the user. Columbia products are not to be used to lift people or to lift anything over people.

20AAM DAVIT CRANE DIMENSIONS

Shown with Columbia Manual Hoist

All measurements are shown in inches.

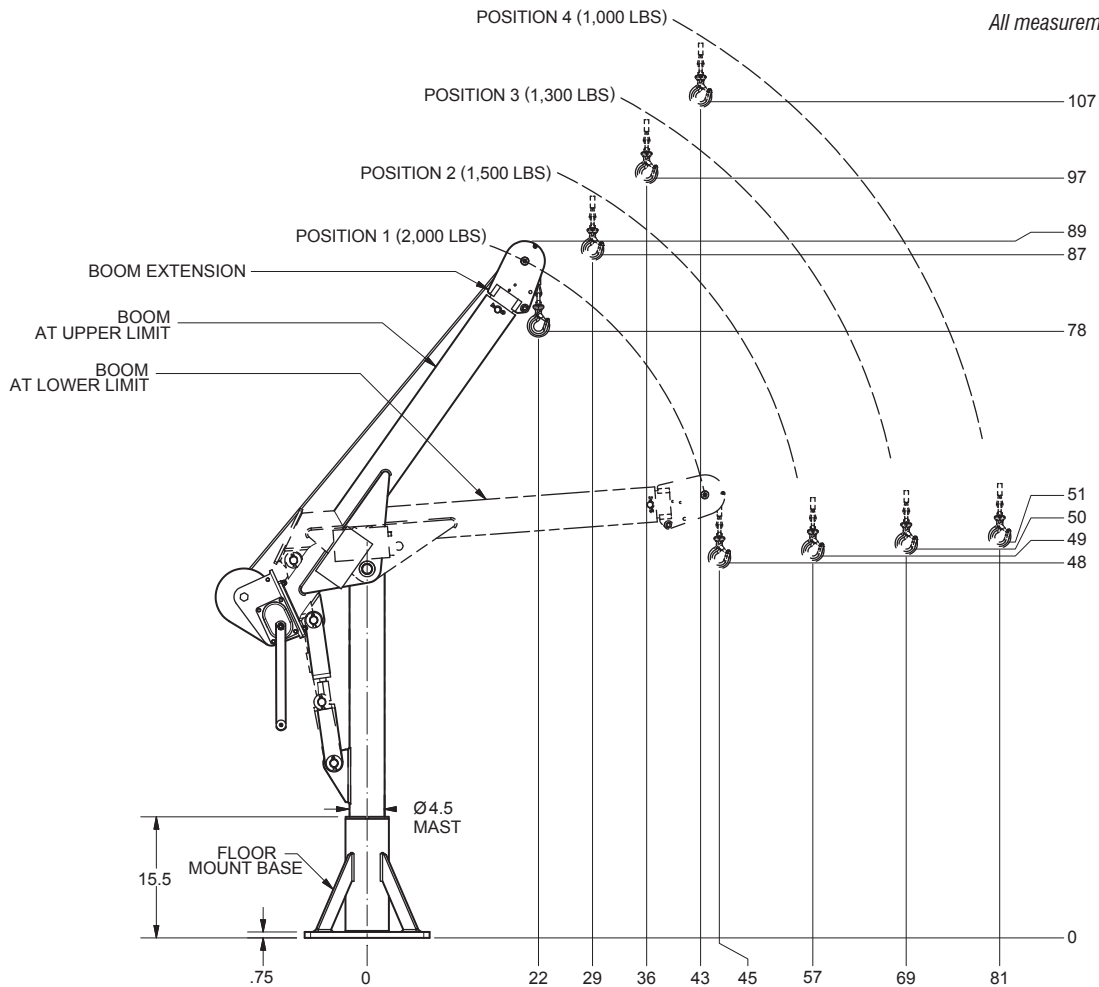

MOUNTING BASES

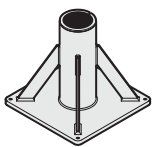

Pedestal base

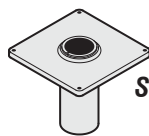

Socket base

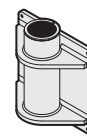

Wall-mounted base

